

NEW!
VCM 70 L

HIGH-PERFORMANCE BOWL CUTTERS FOR THE BUTCHER TRADE

.....

Bowl cutters CM 50, 70, 90, 120 L
Vacuum bowl cutters VCM 70, 120 L
Software



K+G WETTER

K+G WETTER

THE PERFECT CUT WITH EASE

Page 5

BOWL CUTTERS FROM K+G WETTER
ARE THE ANSWER

Page 6

CUTMIX 50, 70 AND 90 L

Robust, capable tools with a stable frame

Page 10

CUTMIX 120 L

Stability meets ergonomics

Page 12

VACUUM CUTMIX 70 AND 120 L

Sophisticated flavour enhancers

Page 14

CUTCONTROL AND CUTVISION

Clever software for smooth processes

Page 16

YOUR OPTIONS

Page 18

“As an organic farm with its own butcher’s shop we give everything to ensure pure enjoyment. That’s why we consciously rely on K+G Wetter’s high-quality technology.”

Florian Holzmayr, Managing Director Packhof Butchery



THE PERFECT CUT WITH EASE

Bowl cutters and vacuum bowl cutters
from K+G Wetter

Good taste knows no compromises – especially in food processing. Our cumulative experience therefore flows into our bowl cutters and vacuum bowl cutters, thereby guaranteeing you maximum quality and hygiene. Right from the beginning.

ENGINEERING ART FOR PERFECT CRAFTSMANSHIP

As a world-famous brand of high-quality meat processing machines we know what’s important to the butcher’s craft. Because this is where our roots lie. Discover the difference – and all of the small details that make your work easier. To deliver improvements in safety and smooth processes that pay off immediately. For you. And your customers.



Swing feet

ensure quiet and low-vibration machine operation, serve to achieve the optimum height and inclination of the machines



Bevelled surfaces made of stainless steel

allow cleaning water to flow away reliably



Robust machine frame made of grey cast iron

absorbs vibrations, thereby ensuring low-vibration and quiet operation. The knife shaft is stably integrated into the robust knife shaft arm, which is cast in one piece with the frame. This ensures that the knives operate with the lowest possible spacing from the cutter bowl and knife cover – for the shortest processing times.

In VCM 70 STL the machine frame is completely made of stainless steel.

5 CLEAR ARGUMENTS FOR YOUR SUCCESS

What our solutions offer – and the benefits to you.

1 ROBUST AND CLEVER CONSTRUCTION

SOLID GREY CAST IRON MACHINE FRAME: absorbs vibrations, ensures stability, calm and quiet running and a long service life for your machine

SWING FEET: allow optimal alignment of the bowl cutters and significantly reduce vibrations too

CONTROL CABINET INSIDE THE MACHINE: saves space and is ready for immediate connection, no further wiring or assembly required

2 MAXIMUM HYGIENE

BEVELLED SURFACES MADE OF STAINLESS STEEL: allow cleaning water to flow off reliably

HAND-POLISHED SURFACES: easy to thoroughly clean, nowhere for product deposits to form, thanks to surfaces polished to maximum smoothness

RAISED BOWL EDGE: prevents the sausage meat from overflowing, keeps the machine and environment clean, ensures a higher filling level and improved efficiency

WATER DRAIN PLUG REMOVABLE WITHOUT TOOLS: for quick, hygienic and easy cleaning of the cutter bowl

3 EASY WORKING

TOUCH PANEL: intuitive to use and easy to clean

REMOVABLE BAFFLE PLATE: allows the cutting chamber size to be varied in no time at all for easily creating different textures. The cutting chamber size is adapted to the product.

TEMPERATURE MEASURED DIRECTLY INSIDE THE CUTTING CHAMBER: precise measurement of even the smallest fill quantities

MANUAL UNLOADER: empties the cutter bowl fully and quickly

HYDRAULIC UNLOADER: for the best ergonomics thanks to an even easier working process (available as an option for CM 120 + VCM 120, only in conjunction with hydraulic loading device)

SEPARATE, REPLACEABLE RING ON THE UNLOADER DISC: can be replaced quickly if worn, complete replacement of the unloader disc is unnecessary

COMPACT, HYDRAULIC LOADING: uniform and smooth movement of the meat trolley thanks to the two hydraulic cylinders; prevents material loss and facilitates simple and hygienic cleaning (available as an option for CM 120 + VCM 120)

4 EFFICIENT PROCESSES AND MAXIMUM FLEXIBILITY

CUTCONTROL SOFTWARE:

provides a simple method of managing your recipes to ensure consistent quality. Recipes can be saved and called up via the machine's touch display. The software guides you step by step through the entire process.

CUTVISION SOFTWARE:

reliably documents all production and quality-relevant data for quality management purposes

3 DIFFERENT KNIFE TYPES:

universal, raw sausage and fine sausage knives form perfectly coordinated cutting systems for different types of sausages and products

VARIABLE BOWL AND KNIFE SPEEDS:

optimal adjustment of bowl and knife speed to the respective product

OPTIONAL T2M-R OR STL DRIVES:

easy to operate via the intuitive touch panel, digital displays provide information on product temperature, knife speed, bowl revolutions and running time

T2M-R 2 speeds, reverse mixing speed mode	STL stepless drive, variable speeds
<ul style="list-style-type: none"> – simple and robust technology – 2 speeds each for cutting and mixing (forwards and backwards) – 2-speed bowl drive – standard temperature shutoff – optional: limit switch for bowl revolutions and time 	<ul style="list-style-type: none"> – infinitely variable knife shaft speed: 40–5000 RPM – infinitely variable mixing speed: 40–500 RPM – up to 6 forward and 2 reverse speeds can be saved – alternatively, freely selectable number of forward and reverse operations – limit switch for temperature, bowl revolutions and time is fitted as standard



CutControl

for efficient processes and reproducible results

5 SAFETY

LABYRINTH SEALING DISC ON THE KNIFE SHAFT: reliably protects the knife shaft bearings by preventing material from penetrating – for trouble-free operation even at maximum speeds

WAVE GASKETS ON THE MACHINE DOORS: cleaning water cannot penetrate into the machine. The gaskets' wave profile interrupts the water jet, thereby reliably preventing penetration.

EMERGENCY STOP BUTTON: rapidly brings knife and bowl to a standstill

QUALITY MADE IN GERMANY: worthwhile investment thanks to long service life, high reliability and reliable technology

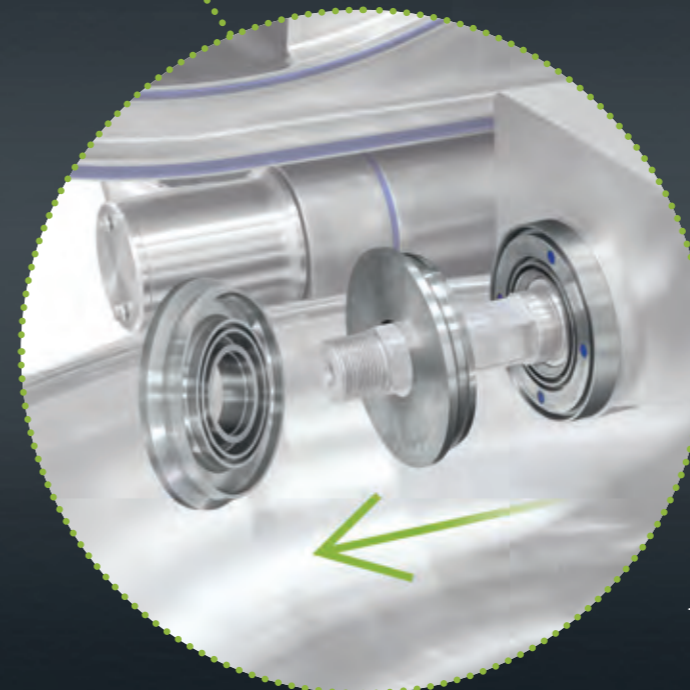

Emergency stop button

for bringing to a rapid stop and maximum safety



Labyrinth sealing disc

for maximum protection of the knife shaft bearings

3 DIFFERENT KNIFE TYPES

For the perfect cut to master a wide range of challenges

Standard cutter head with six serrated knives, for universal use

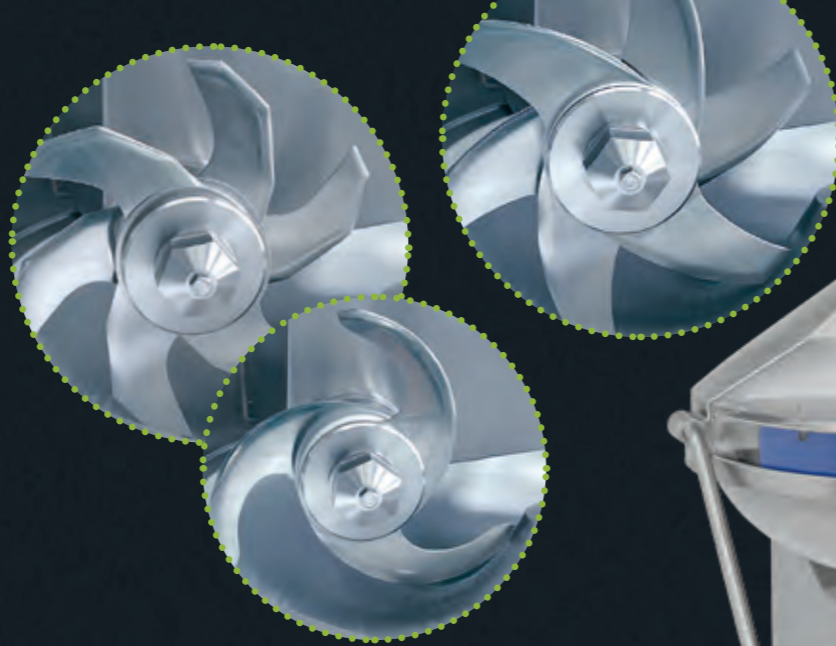

Fine sausage cutter head with six knives, for extremely fine boiled sausage meat and high-speed bowl cutters

Raw sausage cutter head with three sickle knives, ideal for raw sausage meat

CUTMIX 50, 70 AND 90 L

Robust, capable tools with a stable frame

A Cutmix simply remains unflappable: All of the bowl cutters in this range are fitted with a robust machine frame made of stable grey cast iron – for low-vibration and low-noise operation and a long service life for your bowl cutter.

FINE CUT

A further benefit is the variable-size cutting chamber of our Cutmix models. A removable baffle plate means that its size can be effortlessly increased or decreased. This allows you to flexibly adjust the texture of your sausage meat from coarse to fine – according to your individual requirements.

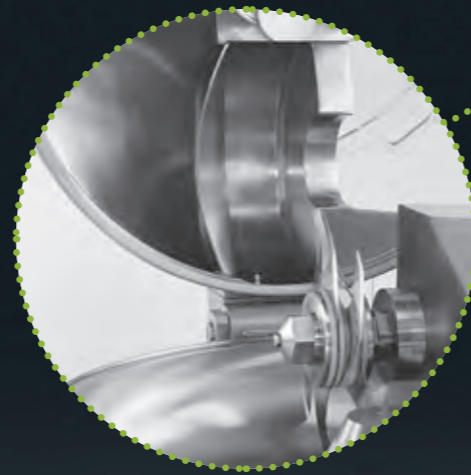

REMOVABLE BAFFLE PLATE

rapidly adapts your bowl cutter to various requirements

DIMENSIONS

Cutmix 50 L / 70 L / 90 L

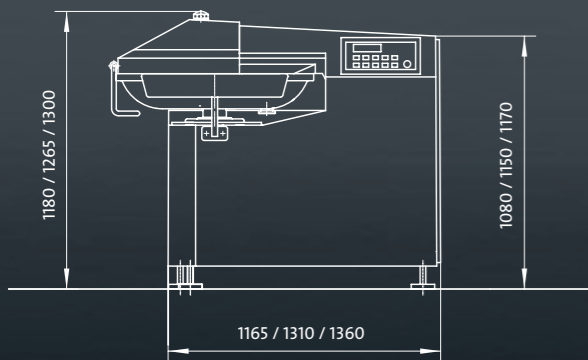

All dimensions in mm

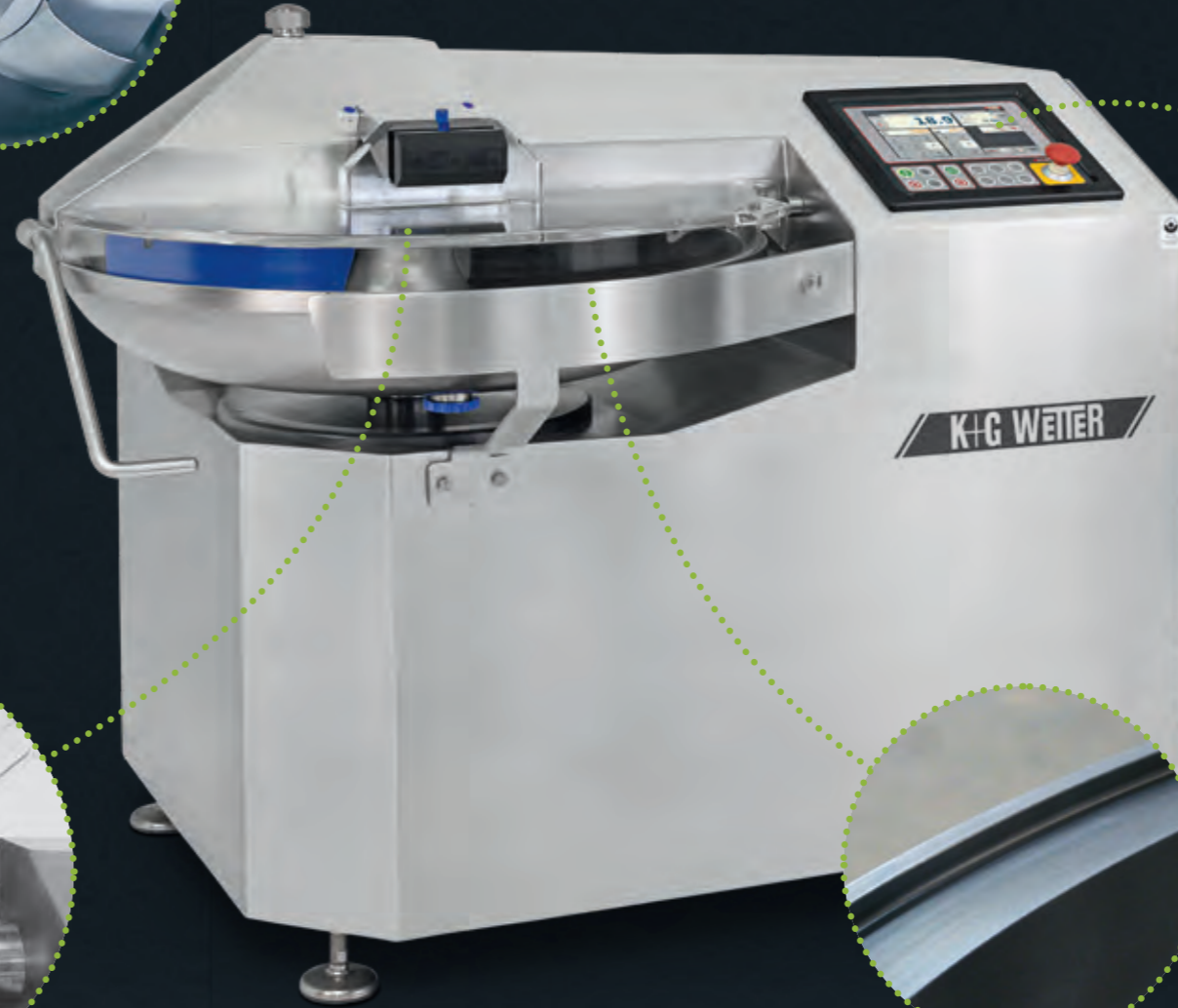
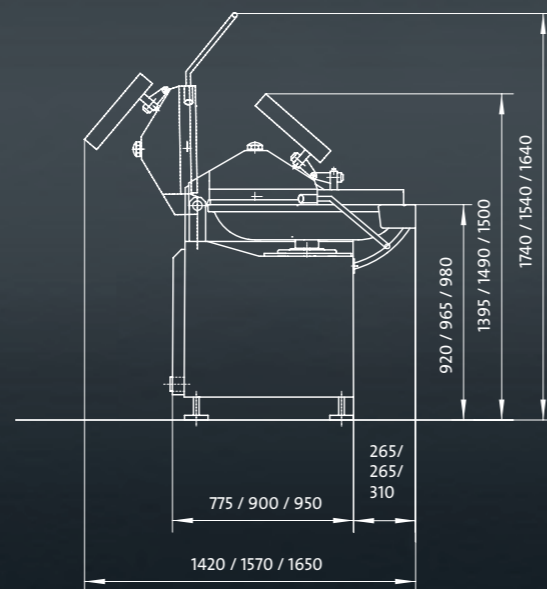

All equipment options for the Cutmix 50–90 litres can be found on pages 18 and 19 of this brochure.



TOUCH PANEL

ensures intuitive operation and simple control

RAISED BOWL EDGE

enables clean working, improves hygiene and prevents product losses

TECHNICAL SPECIFICATIONS

	CM 50 STL	CM 50 T2M-R	CM 70 STL	CM 70 T2M-R	CM 90 STL	CM 90 T2M-R
Type	450	450	470	470	490	490
Version	-	-	-	standard	more powerful drive	-
Electrical specifications	Operating voltage (standard)	400 V / 50 Hz	400 V / 50 Hz	400 V / 50 Hz	400 V / 50 Hz	400 V / 50 Hz
	Rated power	16 kW	11,9 kW	24,8 kW	18,5 kW	22,3 kW
	Customer-side incoming supply fuse	35 A gG	35 A gG	50 A gG	50 A gG	50 A gG
	Leakage current 400 V / 50 Hz typical / maximum inrush	34/192 mA	-	34/192 mA	-	34/192 mA
Rotational speeds	Knife shaft	40–5000 min ⁻¹	1500/3000 min ⁻¹ 1800/3600 min ⁻¹ (optional)	40–5000 min ⁻¹	1500/3000 min ⁻¹ 1800/3600 min ⁻¹ (optional)	40–5000 min ⁻¹ 1500/3000 min ⁻¹ 1800/3600 min ⁻¹ (optional)
	Mixing speed (forward and reverse)	40–500 min ⁻¹	75/150 min ⁻¹	40–500 min ⁻¹	75/150 min ⁻¹	40–500 min ⁻¹
	Two-speed bowl drive	9/18 min ⁻¹	9/18 min ⁻¹	9/18 min ⁻¹	9/18 min ⁻¹	-
	Infinitely variable bowl drive (optional)	5–18 min ⁻¹	-	5–18 min ⁻¹	-	5–18 min ⁻¹
Optimum batch sizes boiled/cooked/raw sausage	40/35/23 kg	40/35/23 kg	56/49/32 kg	56/49/32 kg	72/63/41 kg	72/63/41 kg
Weight	Excluding unloader	950 kg	950 kg	1150 kg	1140 kg	1160 kg
	Including unloader	-	-	1250 kg	1240 kg	1260 kg



HYDRAULIC LOADING

facilitates ergonomic operation and reduces loading time

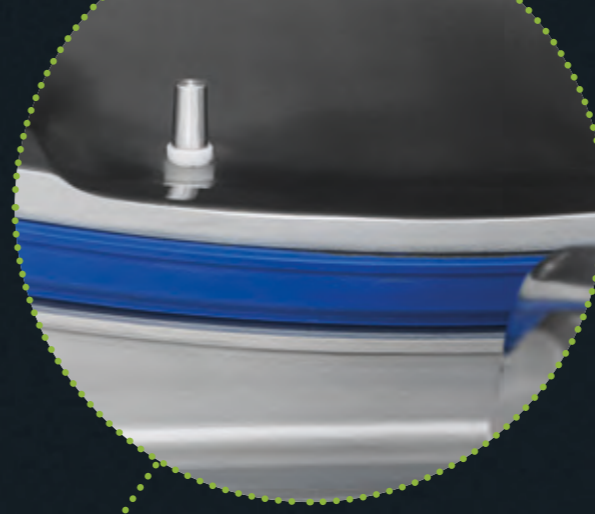

EXACT TEMPERATURE MEASUREMENT

by recording the values directly inside the cutting chamber

CUTMIX 120 L

Stability meets ergonomics

Especially when processing large quantities, making light work of the job is particularly important. Our CM 120 L therefore features clever details that will noticeably alleviate your workload and protect your health during day-to-day activities.

HYDRAULIC LOADING AND UNLOADING

Whether loader or unloader: Both can, as required, be hydraulically controlled with the CM 120 L. This allows you to load and unload your cutter bowl fully automatically and highly precisely, without you having to lift heavy loads yourself.

TECHNICAL SPECIFICATIONS

		CM 120 STL	CM 120 T2M-R
Type		420	420
Electrical specifications	Operating voltage (standard)	400V / 50 Hz	400V / 50 Hz
	Rated power	42,5 kW	43 kW
	Customer-side incoming supply fuse	100 A gG	100 A gG
	Leakage current 400 V / 50 Hz typical / maximum inrush	34/192 mA	-
Rotational speeds	Knife shaft	40–5000 min ⁻¹	1500/3000 min ⁻¹ 1800/3600 min ⁻¹ (optional)
	Mixing speed (forward and reverse)	40–500 min ⁻¹	75/150 min ⁻¹
	Two-speed bowl drive	-	9/18 min ⁻¹
	Infinitely variable bowl drive	5–18 min ⁻¹	-
Optimum batch sizes boiled/cooked/raw sausage		96/84/54 kg	96/84/54 kg
Weight	Excl. unloader	1540 kg	1490 kg
	Incl. unloader	1650 kg	1600 kg
	Loading	350 kg	350 kg



ROBUST CAST IRON FRAME

for stability and low-vibration operation even at maximum speeds

DIMENSIONS

Cutmix 120 L

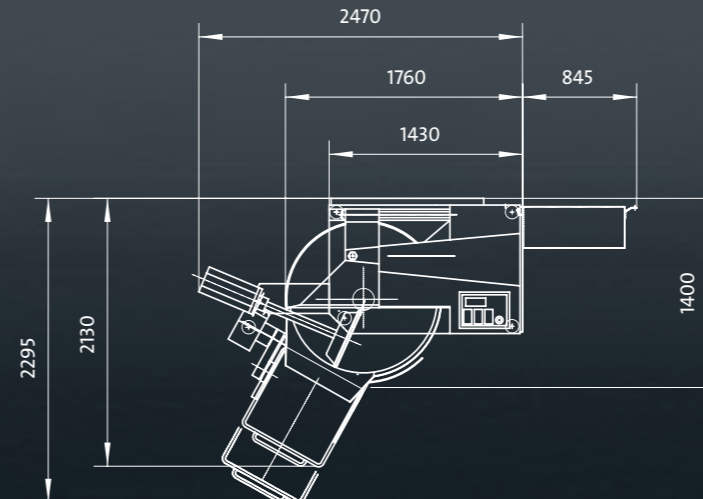
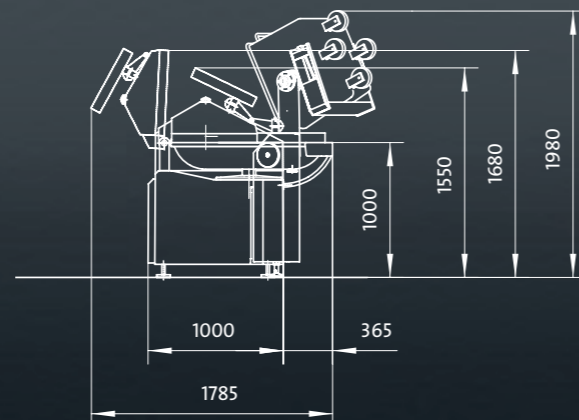
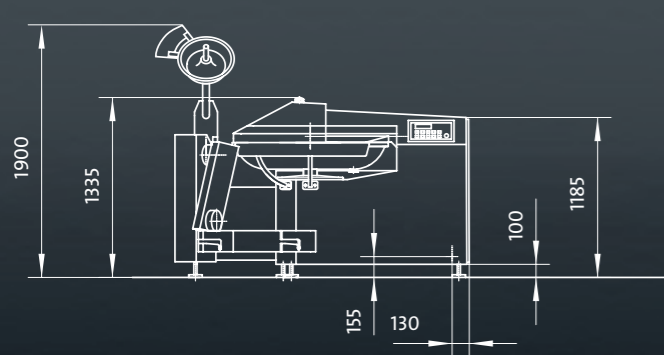

All dimensions in mm

COOKING SYSTEM (OPTIONAL)

allows the rapid production of cooked sausages with no pre-blanching at all

VACUUM CUTMIX 70 AND 120 L

Sophisticated flavour enhancers

Cutting, mixing and emulsifying under vacuum raises your product quality to an even more impressive level. Of course, our vacuum cutters also simultaneously offer all the strengths of the Cutmix range – primarily a robust design coupled with clever details that enable efficient working to the highest standard of hygiene.

GUARANTEED ENJOYMENT

You can easily adjust the intensity of the vacuum using the touch panel. A standard vacuum regulator ensures the selected value remains constant throughout the entire cutting process. The benefits of producing sausage meat under vacuum conditions become fully apparent with this system – delivering consistent quality you can rely on.

DIMENSIONS

Vacuum Cutmix 120 L

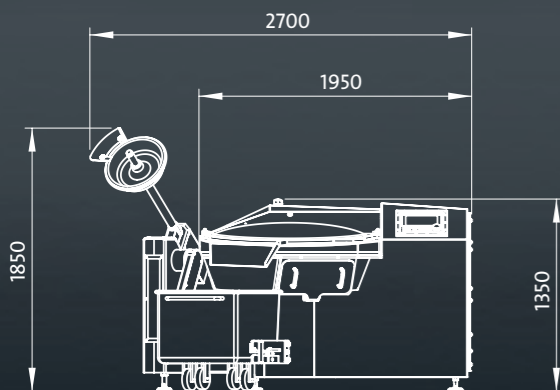

Vacuum Cutmix 70 L

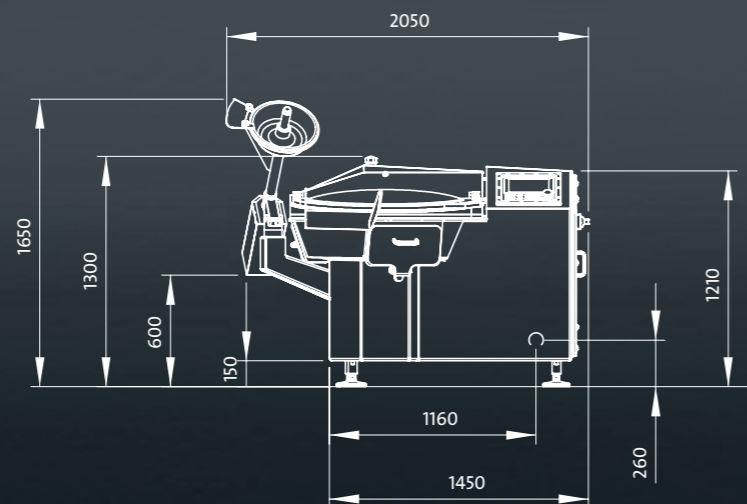

All dimensions in mm

THE BENEFITS OF OUR VACUUM TECHNOLOGY

- firmer and more compact sausage meats
- no air trapped in the sausage meat, significantly extending end product shelf life
- no discoloration of the end product
- the finished sausages have a crisp bite and intensive taste

All equipment options for the Vacuum Cutmix 70 and 120 litres can be found on pages 18 and 19 of this brochure.



LARGE CLEANING ACCESS POINTS

reliably facilitate hygienic machine cleaning

BEVELLED SURFACES

allow cleaning water to completely run off, preventing ponding

TECHNICAL SPECIFICATIONS

		VCM 70 STL	VCM 120 STL	VCM 120 T2M-R
		480	506	506
Electrical specifications	Type	480	506	506
	Operating voltage (standard)	400V / 50 Hz	400V / 50 Hz	400V / 50 Hz
	Rated power (incl. vacuum pump)	25,7 kW	47 kW	47 kW
	Rated current (incl. vacuum pump)	50,2 A	95 A	95 A
	Customer-side incoming supply fuse	63 A gG	100 A gG	100 A gG
Rotational speeds	Leakage current 400 V / 50 Hz typical / maximum inrush	34/192 mA	34/192 mA	-
	Knife shaft	40–5000 min ⁻¹	40–5000 min ⁻¹	1500/3000 min ⁻¹ 1800/3600 min ⁻¹ (optional)
	Mixing speed (forward and reverse)	40–500 min ⁻¹	40–500 min ⁻¹	75/150 min ⁻¹
	Two-speed bowl drive	9/18 min ⁻¹	-	9/18 min ⁻¹
Integrated vacuum pump	Infinitely variable bowl drive	5–18 min ⁻¹	5–18 min ⁻¹	-
	Pump type	Water ring	Water ring	Water ring
	Vacuum capacity	27 m ³ /h	120 m ³ /h	120 m ³ /h
	Water consumption (only during evacuation)	approx. 3,3 l/min	approx. 5,5 l/min	approx. 5,5 l/min
Cooking/cooling system	Water connection line pressure	1 bar	1 bar	1 bar
	Water consumption during cooling mode	approx. 12 l/min	approx. 12 l/min	-
	Water pressure	2–3 bar	2–3 bar	-
	Steam consumption during cooking mode	typ. 10...15 kg/batch	typ. 15 kg/batch	-
Weight	Steam pressure / temperature	1–2 bar / 120–133°C	1–2 bar / 120–133°C	-
	Optimum batch sizes boiled/cooked/raw sausage	56/49/32 kg	96/84/54 kg	96/84/54 kg
	Excluding unloader	1480 kg	2410 kg	2360 kg
Loading device	Including unloader	1580 kg	2520 kg	2470 kg
	Weight	-	350 kg	350 kg

CUTCONTROL AND CUTVISION

Clever software for
smooth processes

Efficient processes, reproducible quality and reliable documentation of all production steps: All these contribute to adding value, which even craft businesses no longer wish – or need – to forego. As an option, we can therefore equip your bowl cutters and vacuum bowl cutters with intelligent software that combines high-level functionality with ease of use.

AN ESPECIALLY STRONG DUO

While CutControl, an automatic program controller with digital recipe management, leads you step-by-step through the entire production process, CutVision reliably and comprehensively ensures the provision of all quality-relevant data required for the creation of sausages and other products – entirely automatically once the bowl cutter is started.

**EASY TO
OPERATE**

*software thanks to our
intuitive touch panel*



CUTVISION

*reliably backs up all relevant data
for optimal sausage production*

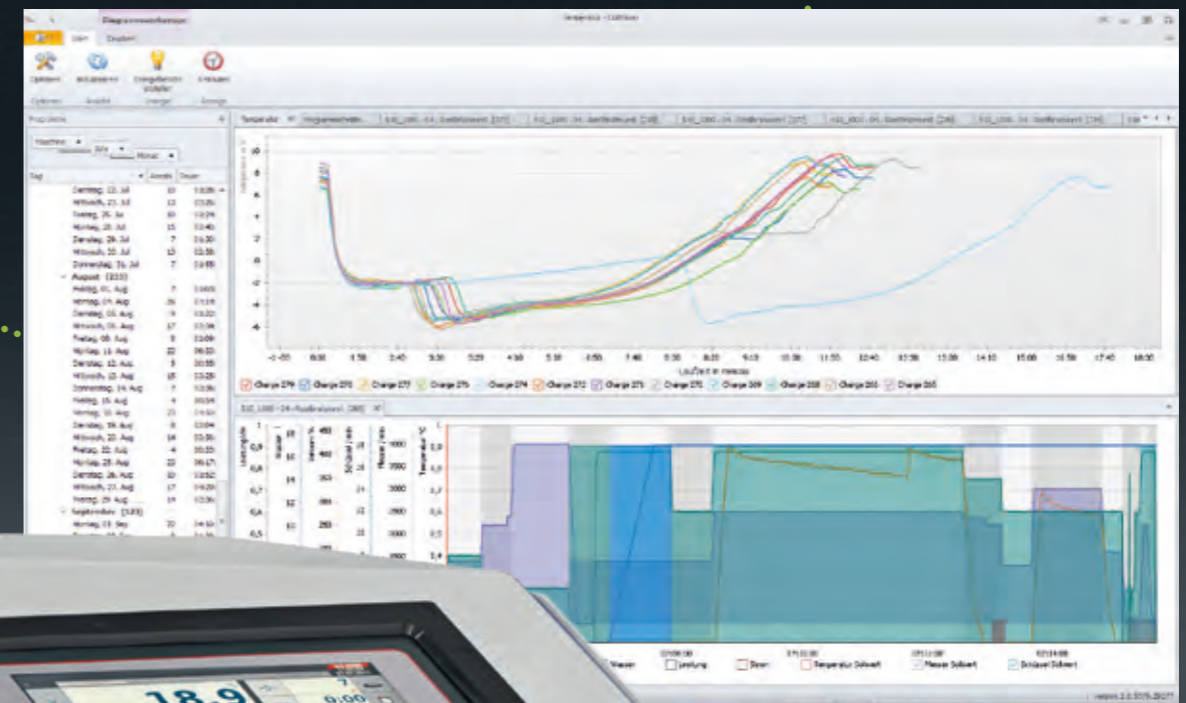

YOUR OPTIONS

The highest quality standards are already built into the DNA of K+G Wetter machines. You can add further clever options to all of the machines to deliver the greatest possible flexibility. We would be pleased to help you tailor your machine to suit your individual requirements.



	CM 50 T2M-R	CM 50 STL	CM 70 T2M-R	CM 70 STL	CM 90 T2M-R		CM 90 STL	CM 120 T2M-R	CM 120 STL	VCM 70 STL	VCM 120 T2M-R	VCM 120 STL
Electric knife cover drive	optional	optional	optional	optional	—		✓	✓	✓	✓	✓	✓
Manual unloader	—	—	optional	optional	optional		optional	optional	optional	optional	optional	optional
Hydraulic unloader	—	—	—	—	—		—	optional (together with hydraulic loading device)	optional (together with hydraulic loading device)	—	optional (together with hydraulic loading device)	optional (together with hydraulic loading device)
Loading device	—	—	—	—	—		—	optional	optional	—	optional	optional
Cooking/cooling system	—	—	—	—	—		—	—	—	optional	optional	optional
CutControl	—	optional	—	optional	—		optional	—	optional	optional	—	optional
CutVision	—	optional	—	optional	—		optional	—	optional	optional	—	optional
2-speed knife drive	✓	—	✓	—	✓		—	✓	—	—	✓	—
Infinitely variable knife drive	—	✓	—	✓	—		✓	—	✓	✓	—	✓
Temperature shutoff	✓	✓	✓	✓	✓		✓	✓	✓	✓	✓	✓
Time/revolution shutoff	optional	✓	optional	✓	optional		✓	optional	✓	✓	optional	✓
2-speed bowl drive	✓	✓	✓	✓	✓		—	✓	—	—	✓	—
Infinitely variable bowl drive	—	optional	—	optional	—		✓	—	✓	✓	—	✓



MADE IN GERMANY

ALL-ROUND SHARPENING SERVICE

.....
Directly from the professionals

If your cutting tool's performance drops following intensive use, we will sharpen it like new in next to no time – secure transport included. For further information please visit: kgwetter.de/schleifservice

A GOOD DECISION

.....
Quality pays off

Our machines help you earn your money. We are aware of this responsibility – and this is apparent in our high-quality solutions. Thought through down to the last detail, they ensure decades of efficient processes and the highest degree of safety for your business. You can be certain you made the right choice.

COME AND SEE US

We would be delighted to show you where and how our bowl cutters, grinders and mixers for the butcher trade and industrial customers are made. During a tour of our production facilities in beautiful Hesse, you will sense what has always driven us at K+G Wetter: the passion to keep setting standards with our ideas. For pure enjoyment – and your success. Worldwide.

Find out for yourself. We look forward to meeting you!

K+G WETTER

K+G WETTER GmbH
Goldbergstraße 21
35216 Biedenkopf-Breidenstein

Tel. +49 (0) 64 61 / 98 40 - 0
Fax +49 (0) 64 61 / 98 40 - 25

info@kgwetter.de
www.kgwetter.de